

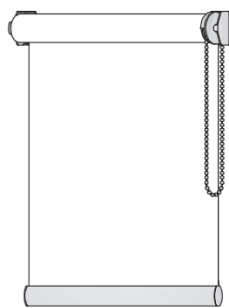

USO INTERNO

TULIPANO FILTRANTE



RULLO XS
A CATENA O MOLLA

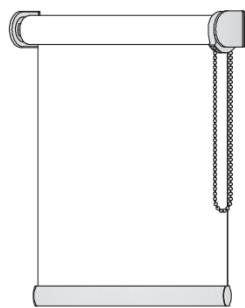

RULLO A CATENA
CON O SENZA
CASSONETTO

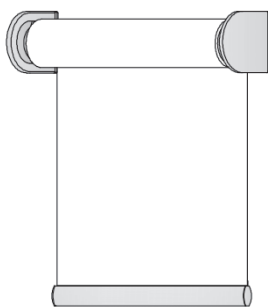

RULLO A MOTORE
CON O SENZA
CASSONETTO

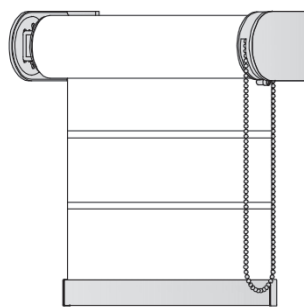

RULLO 70 XL
A CATENA O MOTORE
CON O SENZA
CASSONETTO

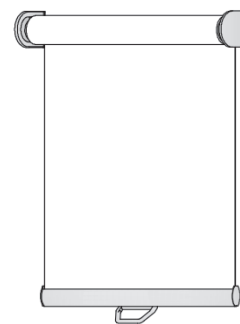

RULLO A MOLLA
CON O SENZA
CASSONETTO

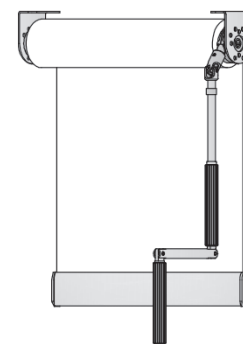

RULLO AD ARGANELLO
CON O SENZA
CASSONETTO

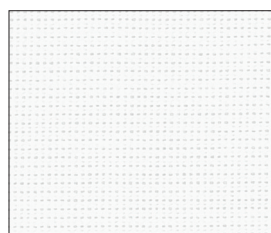
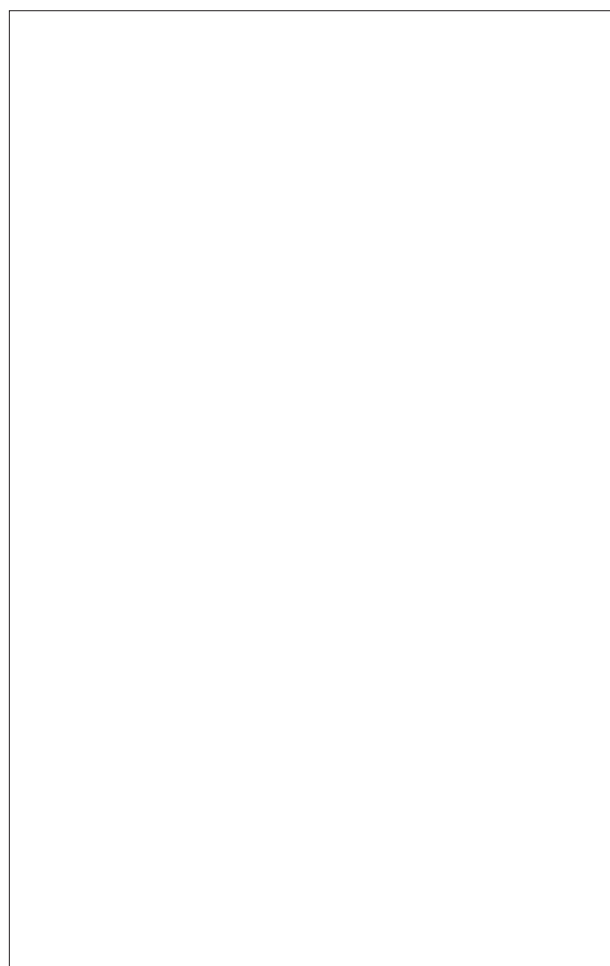

GT.100
Bianco

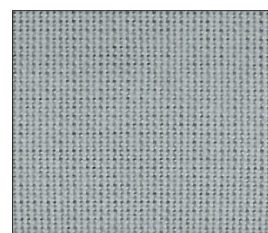

GT.601
Grigio chiaro

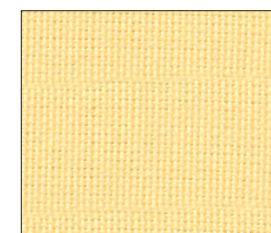

GT.404
Giallo



GT.401
Avorio

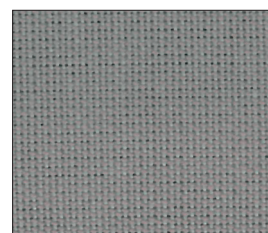

GT.603
Grigio

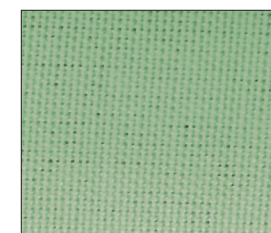

GT.502
Verde



GT.861
Beige

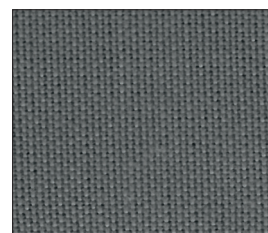

GT.867
Antracite

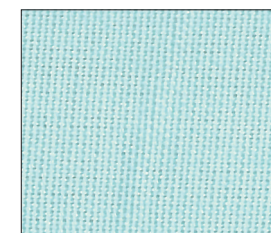

GT.200
Celeste

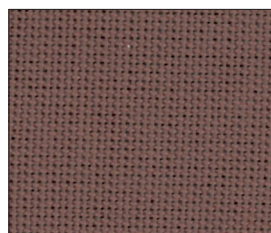

GT.863
Marrone chiaro



GT.701
Rosso

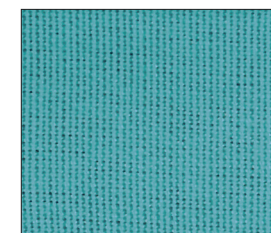

GT.202
Azzurro

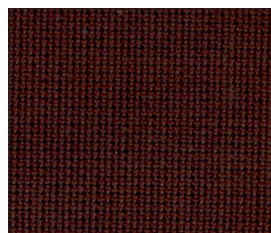

GT.865
Marrone scuro

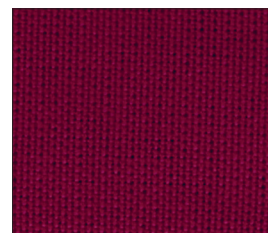

GT.702
Vinaccia



GT.204
Blu

TULIPANO FILTRANTE

DESCRIZIONE MATERIALE

Description of the material
Beschreibung des Materials

60 % POLIESTERE FR - 40 % POLIESTERE
60 % Polyester fr - 40 % Polyester
60 % Polyester fr - 40 % Polyester

PESO (g/mq.)

Weight (g/mq.)
Gewicht (g/mq.)

265 ca.

SPESSORE (mm.)

Thickness (mm.)
Dicke (mm.)

0,45 ca.

LARGHEZZA TESSUTO

Fabric width
Stoffbreite

330 cm.

COMPORAMENTO ALLA FIAMMA

Fire reaction
Feuerverhalten

IGNIFUGO CLASSE 1
Class 1 fire-retardant
Feuerhemmend Klasse 1



MANUTENZIONE

Maintenance
Wartung



LAVAGGIO CONSIGLIATO A SECCO,
CON PERCLOROETILENE
E PROGRAMMA DELICATO
Delicate program dry-cleaning, with
ethylene perchlorate is recommended
Die chemische Reinigung mit erchlorat
aethylen feinwasch Programm,
ist empfohlen



LAVAGGIO DELICATO MAX.
30°C CENTRIFUGAZIONE
RIDOTTA
Delicate washing max 30°C
with reduced centrifugation
Feinwaschen max 30°C
reduziertes Schleudern



LAVAGGIO A MANO NON
TORCERE
Hand washing do not
twist
Handwaschen nicht
auswinden



EVITARE L'USO DEL CLORO
NON CANDEGGIARE
Avoid the use of chlorine do
not bleach
Der gebrauch des Chlores it
zu vermeiden nicht bleichen



STIRATURA CON TEMP.
MAX. 110°C INTERPORRE
PANNI UMIDI
Ironing max temp. 110°C
with humid cloth
Bügeln mit T. max 110°C
ein feuchtes Tuches ist
dazwischen zu legen

COMPORAMENTO ALLA LUCE

Behaviour to the light
Lichtreflektion

COLOR ± 2%	R **	T **	A **
GT.100	57	43	0
GT.401	57	40	3
GT.861	44	25	31
GT.863	10	4	86
GT.865	8	4	88
GT.601	48	30	22
GT.603	29	16	55
GT.867	16	10	74
GT.404	60	38	2
GT.502	46	31	23
GT.200	46	31	23
GT.202	31	17	52
GT.204	7	5	88
GT.701	8	5	87
GT.702	8	4	88

** R= Riflessione; T= Trasmissione; A= Assorbimento

COMPORAMENTO AL CALORE

Behaviour to the heat
Warmereflektion

COLOR ± 2%	R **	T **	A **
GT.100	57	43	0
GT.401	57	40	3
GT.861	51	31	18
GT.863	40	20	40
GT.865	33	22	45
GT.601	53	34	13
GT.603	46	30	24
GT.867	39	26	35
GT.404	53	34	13
GT.502	51	36	13
GT.200	51	36	13
GT.202	47	31	22
GT.204	33	22	45
GT.701	37	24	39
GT.702	38	19	43